



PRODUCT SPECIFICATION

288 Ckt Vertical Through-Hole DDR4 DIMM 2.4mm Seating Plane

1.0 SCOPE

This Product Specification covers the 0.85 mm centerline gold plated DDR4 DIMM edge card connector for 1.40 +/- 0.10 thick memory modules.

2.0 PRODUCT DESCRIPTION

2.1 PRODUCT NAME AND SERIES NUMBER(S)

<u>Series Number</u>	<u>Product Descriptions</u>
78726	288Ckt, Vertical Through-Hole, DDR4 Dimm, 2.4mm Seating Plane

2.2 DIMENSIONS, MATERIALS, PLATINGS AND MARKINGS

See the appropriate Sales Drawings for information on dimensions, materials, plating and markings, recommended module outlines and footprint Specifications.

2.3 SAFETY AGENCY APPROVALS

UL File: E29179
CSA File: 1409726 (LR19980)

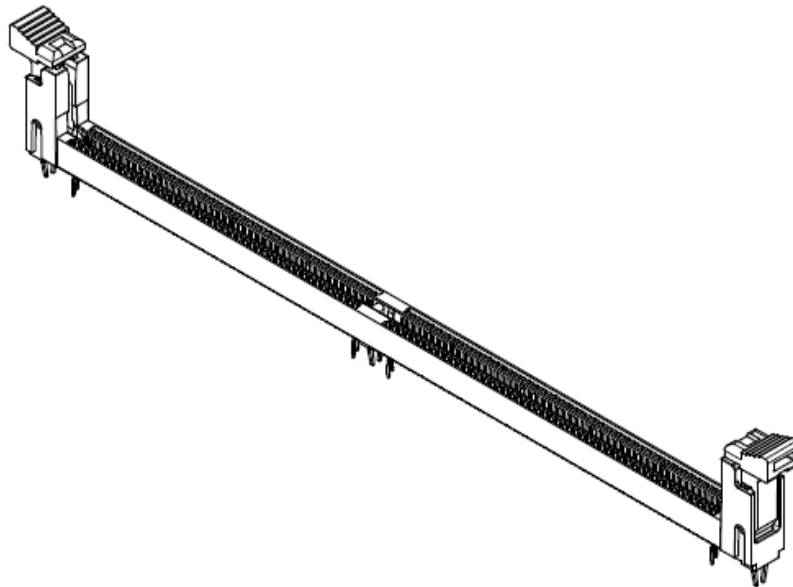

REVISION: A	ECR/ECN INFORMATION: EC No: S2015-0737 DATE: 2015/04/30	TITLE: DDR4 DIMM, 0.85MM PITCH, 288CKTS, VERTICAL THRU - HOLE	SHEET No. 1 of 7
DOCUMENT NUMBER: PS-78726-001	CREATED / REVISED BY: MELVIN SOH	CHECKED BY: CG TAN	APPROVED BY: SH LENI



PRODUCT SPECIFICATION

3.0 APPLICABLE DOCUMENTS AND SPECIFICATIONS

Refer to the appropriate sales drawings and other sections of this specification for the necessary referenced documents and specifications. In the event of conflict between the requirements of this specification and the product drawings, the product drawings shall take precedence. In the event of conflict between the requirements of this specification and reference documents, this specification shall take precedence.

4.0 RATINGS

4.1 VOLTAGE

29 Volts AC (RMS) / DC

4.2 CURRENT

0.75 Amps/ pin

4.3 TEMPERATURE

Operating Temperature: -55°C ~ +85°C

Non-Operating Temperature: -55°C ~ +85°C

4.4 FIELD LIFE AND TEMPERATURE

Field Life: 7 Years

Field Temperature: 65°C

5.0 PERFORMANCE

5.1 ELECTRICAL REQUIREMENTS

ITEM	TEST DESCRIPTION	PROCEDURE	REQUIREMENT
1	Low level contact resistance (LLCR) (Initial)	EIA 364-23 – Option 1 Mate connectors. Apply a current of 100 mA maximum and voltage of 20 mV maximum.	10 mΩ Max
2	Low level contact resistance (Change from initial)	EIA 364-23 – Option 1 Mate connectors. Apply a current of 100 mA maximum and voltage of 20 mV maximum.	10 mΩ Max
3	Insulation resistance	EIA-364-21 Unmate & unmount connectors: apply a voltage of 500 VDC between adjacent terminals and between terminals to ground.	1 MΩ Min.
4	Dielectric withstanding voltage	EIA-364-20 - Method B Unmated connectors. Apply 500 VAC for 1 minute between adjacent terminals.	No breakdown

REVISION: A	ECR/ECN INFORMATION: EC No: S2015-0737 DATE: 2015/04/30	TITLE: DDR4 DIMM, 0.85MM PITCH, 288CKTS, VERTICAL THRU - HOLE	SHEET No. 2 of 7
DOCUMENT NUMBER: PS-78726-001	CREATED / REVISED BY: MELVIN SOH	CHECKED BY: CG TAN	APPROVED BY: SH LENI



PRODUCT SPECIFICATION

5.2 MECHANICAL REQUIREMENTS

ITEM	TEST DESCRIPTION	PROCEDURE	REQUIREMENT
5	Insertion force (Module to Connector with latches)	EIA-364-13 – Method B Mate a 1.50 +0.01 mm thickness gauge (GS-010-1) to the connector at a rate of 25.4 mm / min	106.8 N max.
6	Retention force – Terminal	EIA 364-29 – Method C Axial pull out of terminal in the housing at a rate of 25.4 ±6 mm/min.	300gf min per pin
7	Retention force – Fork lock	EIA 364-29 – Method C Axial pull out of fork lock in the housing at a rate of 25.4 ±6 mm/min.	13.3N min per fork lock
8	Durability (Preconditioning)	EIA-364-09 Perform 5 plug / unplug cycles. Rate: 5 cycles/min. max	No evidence of physical damage.
9	Durability	EIA-364-09 Perform 25 plug / unplug cycles. Rate: 5 cycles /min. max	No evidence of physical damage.
10	Vibration	EIA 364-28 Mated connectors Random profile: 5 Hz @ 0.01 g ² /Hz to 20 Hz @ 0.02 g ² /Hz (slope up) 20 Hz to 500 Hz @ 0.02 g ² /Hz (flat) Input acceleration is 3.13 g RMS 10 minutes per axis for all 3 axes on all samples Random control limit tolerance is ± 3 dB Module weight 40 ± 2g with center of gravity 18-20mm from module mating edge.	No evidence of physical Damage No discontinuities of ≥1 microsecond
11	Mechanical Shock	Mated Connectors. Profile: Trapezoidal shock 50g ±10% Duration : 11ms Velocity change : 170 in/sec. ±10% Quantity: Three drops in each of six directions. Total 18 drops per connector Module weight 40 ± 2g with center of gravity 18-20mm from module mating edge.	No evidence of physical Damage No discontinuities of ≥1 microsecond
12	Reseating	EIA 364-09 Manually mate and unmate the connector with module card for 3 cycles. Rate: 5 cycles/min. max.	No evidence of physical damage.

REVISION:	ECR/ECN INFORMATION:	TITLE:	SHEET No.
A	EC No: S2015-0737 DATE: 2015/04/30	DDR4 DIMM, 0.85MM PITCH, 288CKTS, VERTICAL THRU - HOLE	3 of 7
DOCUMENT NUMBER:	CREATED / REVISED BY:	CHECKED BY:	APPROVED BY:
PS-78726-001	MELVIN SOH	CG TAN	SH LENI



PRODUCT SPECIFICATION

13	Latch overstress force	Unmated Connectors. Apply an actuation force on the latch at a rate of 25.4 ± 6 mm / min in the fully open position.	3.5kgf min force held for 10 sec. with no damage.
14	Latch actuation force	Apply an actuation force on the latch at a rate of 25.4 ± 6 mm min with test blade of 1.50 ±0.01 mm (GS-010-1) inserted into connector.	The force to fully actuate the latch open shall be 3.5kgf max. per latch.
15	Module rip out force	Pull up from the center of the test module 1.50 ±0.01mm thick (GS-010-1) with the latches closed at a rate of 25.4 ± 6 mm/min.	9.1kgf min. retention force of the module in connector with no damage
16	Insertion force – Connector to board	EIA-364-05. Unmated connectors. Push connector into applicable PCB at a rate of 12.7 ±3 mm/min. Fork lock PCB hole size 2.45 ±0.05 cm /min	75N Max
17	Retention force - Connector to Board	EIA-364-05. Unmated connectors. Pull or push connector with a force of 0.45kgf on connector mounted on the PCB at a rate of 12.7 ± 3 mm/min. Fork lock PCB hole size 2.45 ± 0.05 mm.	No lifting of connector from applicable PCB.
18	Unmating force – (per pin pair)	EIA-364-13 Pull out 1.30 ±0.01 mm thick (GS-010-2) test blade from connector with latches removed at a rate of 12.7± 3 mm/min	2.02 Kgf Min. for 288 circuit) (14gf per pin pair).

5.3 ENVIRONMENTAL REQUIREMENTS

ITEM	DESCRIPTION	TEST CONDITION	REQUIREMENT										
19	Thermal shock	EIA-364-32, Method A, Table 2, Test Condition 1, Duration A-4. Mate connectors; expose to 10 cycles of: <table border="1" style="margin-left: 20px;"> <thead> <tr> <th>Temperature °C</th> <th>Duration (min)</th> </tr> </thead> <tbody> <tr> <td>-55 +0/-3</td> <td>30</td> </tr> <tr> <td>25 +10/-5</td> <td>5 max</td> </tr> <tr> <td>85 +3/-0</td> <td>30</td> </tr> <tr> <td>25 +10/-5</td> <td>5 max</td> </tr> </tbody> </table>	Temperature °C	Duration (min)	-55 +0/-3	30	25 +10/-5	5 max	85 +3/-0	30	25 +10/-5	5 max	None
Temperature °C	Duration (min)												
-55 +0/-3	30												
25 +10/-5	5 max												
85 +3/-0	30												
25 +10/-5	5 max												
20	Temperature life (Preconditioning)	EIA-364-17, Method A, (without electrical load). Mated connector. Expose 91 hours at 105° ±2°C. Exposure time as per EIA-364-1000, Table 9	None										

REVISION:	ECR/ECN INFORMATION:	TITLE:	SHEET No.
A	EC No: S2015-0737 DATE: 2015/04/30	DDR4 DIMM, 0.85MM PITCH, 288CKTS, VERTICAL THRU - HOLE	4 of 7
DOCUMENT NUMBER:	CREATED / REVISED BY:	CHECKED BY:	APPROVED BY:
PS-78726-001	MELVIN SOH	CG TAN	SH LENI



PRODUCT SPECIFICATION

21	Temperature Life	EIA-364-17, Method A (without electrical load) Mated connector. Expose 165 hours at 105° ±2°C. Exposure time as per EIA-364-1000, Table 8	None								
22	Solderability	Unmated connector. Steam age for 8 hour +/- 15 min. Dip solder tails into solder pot at a temperature of 245 ± 5°C for 5 ± 0.5 seconds. Rate: 25.4 +/-6mm /sec Flux type – ROL0 JESD 22-B-102; Condition C.	Solder coverage: 95% MINIMUM								
23	Resistance to solder heat	EIA-364-56 Dip solder tails into solder pot of 260 ± 5°C for 5 ± 1 seconds Immerse leads to a depth of 1.00 +/-0.2 mm from connector body.	Visual: No Damage or discoloration of connector materials.								
24	Temperature rise	EIA-364 Test Procedure 70. Ten pair contacts in consecutive positions on the same side of the connector are connected in a series circuit (mated condition). A thermocouple is inserted through holes in the socket housing, as close to the contact interface as possible. Supply the rated current.	Maximum Temperature Rise shall not exceed 30°C above ambient.								
25	Cyclic temperature & humidity	As per EIA-364-1000 – Test Group 2, Cyclic temperature and Humidity Cycle the connector between <table border="1" style="margin: 5px auto; border-collapse: collapse;"> <thead> <tr> <th colspan="2">Cycle between temperature and RH</th> </tr> <tr> <th>Temp °C</th> <th>RH %</th> </tr> </thead> <tbody> <tr> <td style="text-align: center;">25 ±3</td> <td style="text-align: center;">80 ±3</td> </tr> <tr> <td style="text-align: center;">65 ±3</td> <td style="text-align: center;">50 ±3</td> </tr> </tbody> </table> Ramp times should be 0.5 hour and dwell times should be 1 hour. Dwell times start when the temperature and humidity have stabilized within the specified levels. Perform 24 such cycles.	Cycle between temperature and RH		Temp °C	RH %	25 ±3	80 ±3	65 ±3	50 ±3	None
Cycle between temperature and RH											
Temp °C	RH %										
25 ±3	80 ±3										
65 ±3	50 ±3										
26	Mixed flowing gas	EIA-364-65, class IIA, Exposure time EIA-364-1000 – Table 4.1. Expose unmated connector for 160 hours in MFG chamber. Expose mated (to same test module mated during temp life preconditioning) connector for 80 hours in MFG chamber.	None								
27	Thermal disturbance	EIA-364-1000 – Table 4. Mated connector. Cycle the connector between 15°C±3°C and 85°C±3°C, as measured on the part. Ramps should be a minimum of 2°C per minute. Dwell times should insure that contacts reach temperature extreme (for a minimum of 5minutes). No humidity control. Perform 10 cycles.	None								

<u>REVISION:</u>	<u>ECR/ECN INFORMATION:</u>	<u>TITLE:</u>	<u>SHEET No.</u>
A	EC No: S2015-0737 DATE: 2015/04/30	DDR4 DIMM, 0.85MM PITCH, 288CKTS, VERTICAL THRU - HOLE	5 of 7
<u>DOCUMENT NUMBER:</u>		<u>CREATED / REVISED BY:</u>	<u>CHECKED BY:</u>
PS-78726-001		MELVIN SOH	CG TAN
		<u>APPROVED BY:</u>	
		SH LENI	



PRODUCT SPECIFICATION

6.0 TEST SEQUENCE

TEST DESCRIPTION SEQUENCE	1	2	3	4	5	6	7	8	9	10	11	12
	Low level contact resistance (Initial)	1	1	1		1						
Durability (preconditioning)	2	2	2									2
Durability					2							
Low level contact resistance (Change from initial)	4,6	4,6,8	3,5,7		3							4,6,8,10,12
Insulation resistance				1, 5								
Dielectric withstanding voltage				2,6								
Temperature life (Preconditioning)												3
Temperature life	3											
Thermal shock		3		3								
Thermal disturbance												9
Cyclic temperature & humidity		5		4								
Mixed flowing gas (Unmated)												5
Mixed flowing gas (mated)												7
Mechanical Shock			6									
Vibration			4									
Reseating	5	7										11
Temperature rise						1						
Solderability							1					
Resistance to solder heat								3				
Insertion Force (Module to connector with latches)									1			
Latch Actuation Force										1		
Latch Overstress Force										2		
Module Ripout Force									2			
Insertion force – Connector to board											1	
Retention force – Connector to Board											2	
Retention Force - Terminal								1,4				
Retention Force – Fork lock								2,5				
Unmating Force (per pin pair)											3	
Sample Size per Test Group	5	5	5	5	5	5	5	6	5	5	5	5

REVISION: A	ECR/ECN INFORMATION: EC No: S2015-0737 DATE: 2015/04/30	TITLE: DDR4 DIMM, 0.85MM PITCH, 288CKTS, VERTICAL THRU - HOLE	SHEET No. 6 of 7
DOCUMENT NUMBER: PS-78726-001	CREATED / REVISED BY: MELVIN SOH	CHECKED BY: CG TAN	APPROVED BY: SH LENI



PRODUCT SPECIFICATION

7.0 PACKAGING

Parts shall be packed in trays and protected against damage during handling, transportation and storage.

8.0 RECOMMENDED Pb-FREE REFLOW PROFILES

Connector should be soldered onto PCB using either the wave soldering technique or the reflow soldering technique according to the table shown below.

Process	Peak Temperature	Duration
Wave	265° C Max (Solder Bath) 220° Max Connector Housing	5 +/-2 sec (wave contact)
Reflow	220°C Max Peak 220° Max Connector Housing	20 to 40 sec Time within 5°C of peak

REVISION: A	ECR/ECN INFORMATION: EC No: S2015-0737 DATE: 2015/04/30	TITLE: DDR4 DIMM, 0.85MM PITCH, 288CKTS, VERTICAL THRU - HOLE	SHEET No. 7 of 7
DOCUMENT NUMBER: PS-78726-001	CREATED / REVISED BY: MELVIN SOH	CHECKED BY: CG TAN	APPROVED BY: SH LENI
<small>TEMPLATE FILENAME: PRODUCT_SPEC\SIZE_A4\{V.1}.DOC</small>			